

MDTA Series

Flat Wire Molded Inductor

Size 6050



FEATURES

- Composite core material allows high saturation currents
- Very low acoustic noise and very low leakage flux noise
- High temperature capability and handles high transient currents
- C-Q200 qualified
- Operating temperature -55 to +155 °C (Including self - temperature rise)
- Quantity: 800pcs

APPLICATION

- DC/DC converters for entertainment/navigation systems
- Power windows / windshield power mirrors / heating and ventilation blowers / HID lighting
- LED driver

Dimensions: [mm]

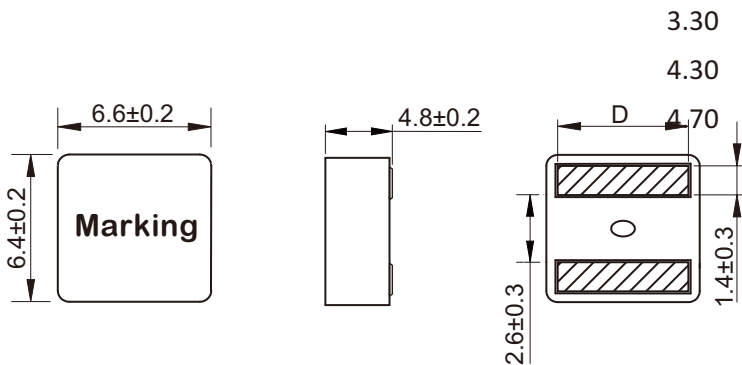

Land Pattern: [mm]

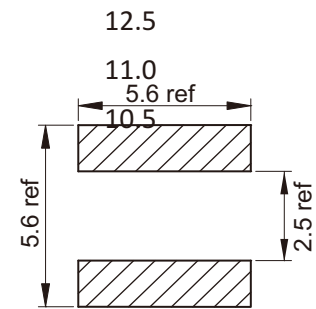

Electrical Properties:

Inductance (μH)	DC Resistance (mΩ)	DC Resistance (mΩ)
16.0	4.18	5.3±0.3
15.0	4.52	5.3±0.3
14.0	5.83	5.3±0.3
13.0	6.30	5.3±0.3
12.0	7.10	5.3±0.3
10.0	8.50	5.2±0.3
8.5	12.5	5.2±0.3
7.0	16.2	5.2±0.3
6.5	18.4	5.2±0.3

Saturation Current will cause L to drop approximately 30%

Temperature Rise Current that causes the specified temperature rise from 25°C ambient.

Soldering Reflow:

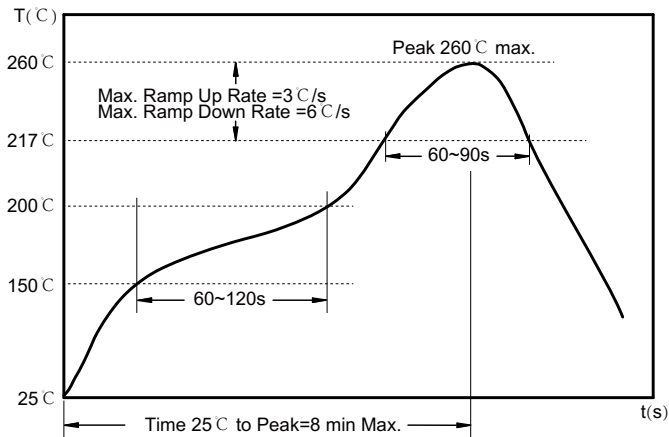

Preheat condition: 150 ~200°C / 60~120 sec.

Allowed time above 217°C : 60~90 sec.

Max temperature: 260°C .

Max time at max temperature: 10 sec.

Allowed Reflow time: 2x max.

Packaging Information:

Tape Dimension :

Series	A0 (mm)	B0 (mm)	D (mm)	P0 (mm)	P1 (mm)	W (mm)	K0 (mm)	E (mm)	T (mm)
MDTA6050	7.0±0.1	6.8±0.1	1.5±0.1	4.0±0.1	12.0±0.1	16.0±0.3	5.3±0.1	1.75±0.1	0.40±0.05

Peel force of top cover tape:

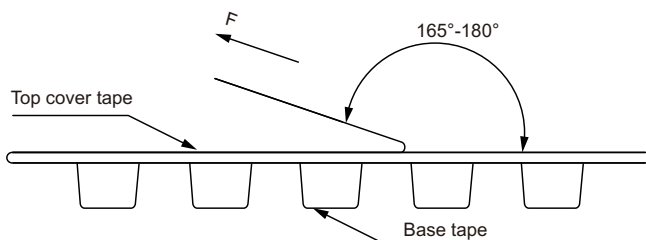

The peel force of top cover tape shall be between 0.1 to 1.3 N

Product Marking:

Marking	Printing (Inductance)
---------	-----------------------

Reel Dimension: [mm]

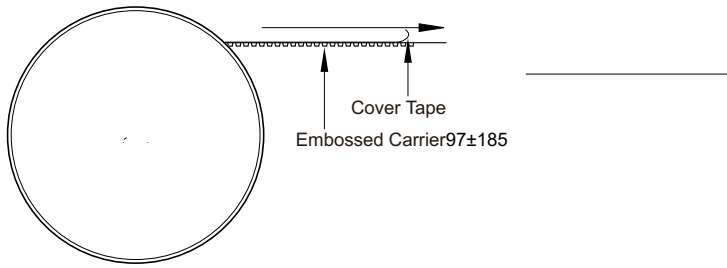

Packaging Quantity: